

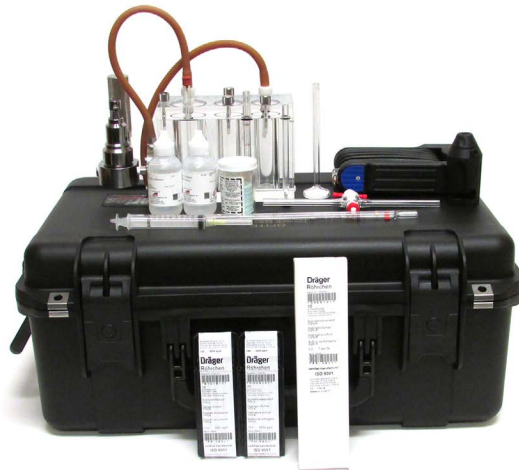

Dependable Products From People You Trust



Garrett Gas Train

Part No. 151-00

Instruction Manual

Updated 4/15/2025

Ver. 7

OFI Testing Equipment, Inc.

11302 Steeplecrest Dr. · Houston, Texas · 77065 · U.S.A.

Tele: 832.320.7300 · Fax: 713.880.9886 · www.ofite.com

Table of Contents

Introduction.....	2
Specifications	2
Components	3
Safety.....	5
Setup.....	6
Sulfide Testing	8
<i>Procedure</i>	<i>9</i>
<i>Calculation</i>	<i>11</i>
Carbonates Testing	12
<i>Procedure</i>	<i>13</i>
<i>Calculation</i>	<i>16</i>
Oil-Based Fluids	17
<i>Procedure</i>	<i>18</i>
<i>Calculation</i>	<i>20</i>
Maintenance.....	21
Diagram	22
Warranty and Return Policy	23

Introduction

The Garrett Gas Train is the most widely used portable instrument for determining the presence and quantity of soluble sulfides and carbonate concentrations in drilling fluid. Soluble sulfides include H_2S as well as sulfide (S^{2-}) and bisulfide (HS^-) ions. Total soluble carbonates include CO_2 as well as carbonate (CO_3^{2-}) and bicarbonate (HCO_3^-) ions.

Mud filtrate is acidified inside the gas train, converting all sulfides to H_2S or all carbonates to CO_2 , depending upon the test. The gas train separates the gas from the liquid and an inert carrier gas transports the gasses through the separate chambers. In chamber three, the gas stream is passed through a Dräger tube, which responds to H_2S or CO_2 by darkening along its length. The stain length is proportional to the amounts of sulfides or carbonates in the filtrate. For qualitative H_2S analysis, lead acetate paper disks may be inserted to determine the presence or absence of sulfides.

The OFITE Garrett Gas Train consists of a transparent train, pressure regulator assembly, CO_2 and N_2O cartridges (sold separately), Dräger tubes for H_2S and carbonate detection, a flowmeter, and a convenient carrying case. For determining active sulfides in oil-based fluids, OFITE offers a separate kit that analyzes whole mud samples.

Specifications

Body Dimensions:

Chamber 1: Depth 3.54" (90 mm) × Diameter 1.52" (39 mm)

Chambers 2 & 3: Depth 3.54" (90 mm) × Diameter 1.18" (30 mm)

Passages between chambers: Diameter 0.08" (2.0 mm)

Dispersion tube:

Stem: Diameter 0.315" (8.0 mm) × Length 5.9" (150 mm)

Frit Diameter: 1.18" (30 mm)

Carrier gas should be inactive with H_2S or sulfide salts, citric acid, demulsifier and isopropanol for the sulfide analysis. CO_2 bulbs are preferred, but nitrogen gas or helium will work. Nitrous oxide bulbs are to be used only for the carbonate analysis. Avoid using compressed air or oxidative gases.

Flowmeter: Floating ball type is preferred, capable of measuring between 200 and 400 cm^3/min . carrier gas.

Syringes and injection tubes must be glass or a plastic type that is inert to sulfides and oil muds.

Components

#142-58	O-ring for HTHP Coupling
#143-00-003	Regulator
#143-02-10	CO ₂ Puncture Head Assembly
#143-02-13	O-ring for Puncture Pin Holder Assembly, CO ₂ Cartridge
#143-02-14	O-ring for Puncture Pin Holder Assembly
#143-03	Barrel for CO ₂ Cartridge
#145-601	Hydrogen Sulfide Test Papers, Package of 100
#151-01	Dispersion Tube
#151-02	Dräger Tube, Hydrogen Sulfide 100/1, Range: 100 - 2,000 PPM (Low Range)
#151-03	Dräger Tube, Hydrogen Sulfide 0.2%/A, Range: 0.2 - 7% by Volume (High Range)
#151-04	Dräger Tube, Carbon Dioxide 0.01%/A, Range: 0.01 - 0.3% by Volume
#151-06	Gas Bag
#151-07	Stopcock
#151-08	API Flow Meter Tube
#151-09	Dräger Hand Pump
#151-10	O-ring for Dräger Pump
#151-11	O-ring for Flow Meter Tube
#151-12	O-ring for 2 nd and 3 rd Chambers
#151-13	O-ring for 1 st Chamber
#151-14	Rubber Hose, ¼" OD × ⅛" ID, 1' Length
#151-14-1	Nylon Tube, 3" Length
#151-16	Rubber Septum, Qty: 2
#151-17	Octyl Alcohol (Defoamer), 2 oz.
#151-53	Carrying Case
#153-34	Glass Pipet, 1 mL × ⅒ mL
#153-40	Glass Pipet, 10 mL × ⅒ mL
#153-63	10 cc Disposable Syringe with Needle
#230-15	*Sulfuric Acid, 5 N, 2 oz., (UN #2796)

Optional:

#153-53-9	Magnetic Stirrer, 1,500 RPM, 115 Barnant (for oil-mud analysis)
#151-20	Kit for Determining Active Sulfides in Oil-Based Fluids:
#151-17	Octyl Alcohol Defoamer, 2 oz.
#151-20-1	*Citric Acid, 2M, Demulsifier, IPA Solution, UN #1219, 16 oz
#151-20-2	Sample Injection Needle
#153-29	Glass-Tip Syringe, 2 CC
#153-29-1	Glass-Tip Syringe, 5 CC
#153-29-2	Glass-Tip Syringe, 10 CC
#153-66	Disposable Syringe, 20CC

#151-00-SP	Spare Parts Kit	QTY
#142-58	O-ring for HTHP Coupling,	4
#143-02-13	O-ring for Puncture Pin Holder Assembly, CO ₂ Cartridge	4
#143-02-14	O-ring for Puncture Pin Holder Assembly	4
#143-05	EZ-Puncture CO ₂ Bulbs, 8-Gram, UN #1013, Package of 10	10
#143-08	EZ-Puncture N ₂ O Bulbs, 8-Gram, UN #1070	5
#145-601	Hydrogen Sulfide Test Papers, Package of 100	2
#151-01	Dispersion Tube	1
#151-02	Dräger Tube, Hydrogen Sulfide 100/1, Range: 100 - 2,000 PPM	2
#151-03	Dräger Tube, Hydrogen Sulfide 0.2%/A, Range: 0.2 - 7% by Volume	2
#151-04	Dräger Tube, Carbon Dioxide 0.01%/A, Range: 0.01 - 0.3% by Volume	2
#151-06	Gas Bag	5
#151-07	Stopcock	1
#151-10	O-ring for Dräger Pump	2
#151-12	O-ring for 2nd and 3rd Chambers	6
#151-13	O-ring for 1st Chamber	3
#151-14	Rubber Hose, ¼" OD × ⅛" ID, 1' Length	4
#151-15	Nylon Fitting for Filter Flow Tube	2
#151-16	Rubber Septum	12
#151-17	Octyl Alcohol (Defoamer), 2 oz.	2
#153-34	Glass Pipet, 1 mL × ⅒ mL	4
#153-40	Glass Pipet, 10 mL × ⅒ mL	2
#153-63	10 cc Disposable Syringe with Needle	12
#230-13	*Sulfuric Acid, 5N, UN #2796, 8 oz	2

Safety

The Garrett Gas Train is designed to test drilling fluids for soluble sulfides, including hydrogen sulfide (H_2S). Hydrogen sulfide is highly toxic and flammable. It smells like rotten eggs, but quickly deadens the sense of smell. You may not be aware of the danger until it is too late.

When performing sulfide testing with the Garrett Gas Train, use extreme caution to avoid breathing any hydrogen sulfide. Use appropriate personal protection equipment at all times.

Nitrous oxide cartridges should not be used as pressure sources when running a standard H_2S test. Under elevated pressures, nitrous oxide can possibly detonate in the presence of grease, oil or carbonaceous materials. Nitrous oxide cartridges are to be used only for the Garrett Gas Train carbonate analysis.

Carbon dioxide and nitrous oxide cartridges are pressurized to approximately 900 psi at 1 atmosphere (sea level). Therefore they should not be placed in airplanes without proper packaging due to the possibility of the cabin depressurization. Nor should they be exposed to direct sunlight for prolonged periods of time.

Hydrogen sulfide is extremely corrosive, so it is important to check all elastomers (o-rings, rubber hoses, etc.) prior to running a test. Special attention should be given to the elastomers that seal each of the three chambers as these may easily be pinched or cut during assembly. Over time the elastomers may become hard and brittle, which will require replacement.

The Garrett Gas Train test requires only a very small amount of pressurization to move the gas between the three chambers. When turning the T-screw on the regulator to initiate pressurization, turn it very slowly as it is easy to overpressurize, resulting in hoses or the rubber septum explosively separating from their connections.

When inserting the Dräger Tube into the hole next to chamber three, be very careful to push downward and vertically, as it will be a tight fit due to the o-ring seal. If inserting at an angle it is possible to break the glass Dräger Tube resulting in injury to the hand or arm.

Dräger Tubes have a shelf life so pay attention to the date stamped on the box. Expired Dräger Tubes can give incorrect results.

Setup

1. Be sure the gas train is clean and dry. Moisture in the train can cause the flowmeter to float erratically and may affect the accuracy of the Dräger tube reading.
2. Place the gas train on a level surface. Remove the top.
3. Add 20 mL of deionized water and 5 drops of octyl defoamer to chamber 1.
4. Place the flowmeter tube into the designated hole between chambers 2 and 3. Make sure the word "Top" or "T" on the tube is pointing upward and that the o-ring seals around the tube.
5. Place the dispersion tube into chamber 1. Place an o-ring into the hole in the lid above chamber 1. Screw the nylon tube holder into the lid just enough to hold the o-ring in place. Carefully place the lid onto the body, making sure the dispersion tube goes into the hole above chamber 1. When the lid is in place, tighten the nylon tube holder. Leave about ¼" empty space below the bottom of the dispersion tube. Make sure the o-ring seals around the tube.
6. Evenly hand-tighten all screws to seal the o-rings.

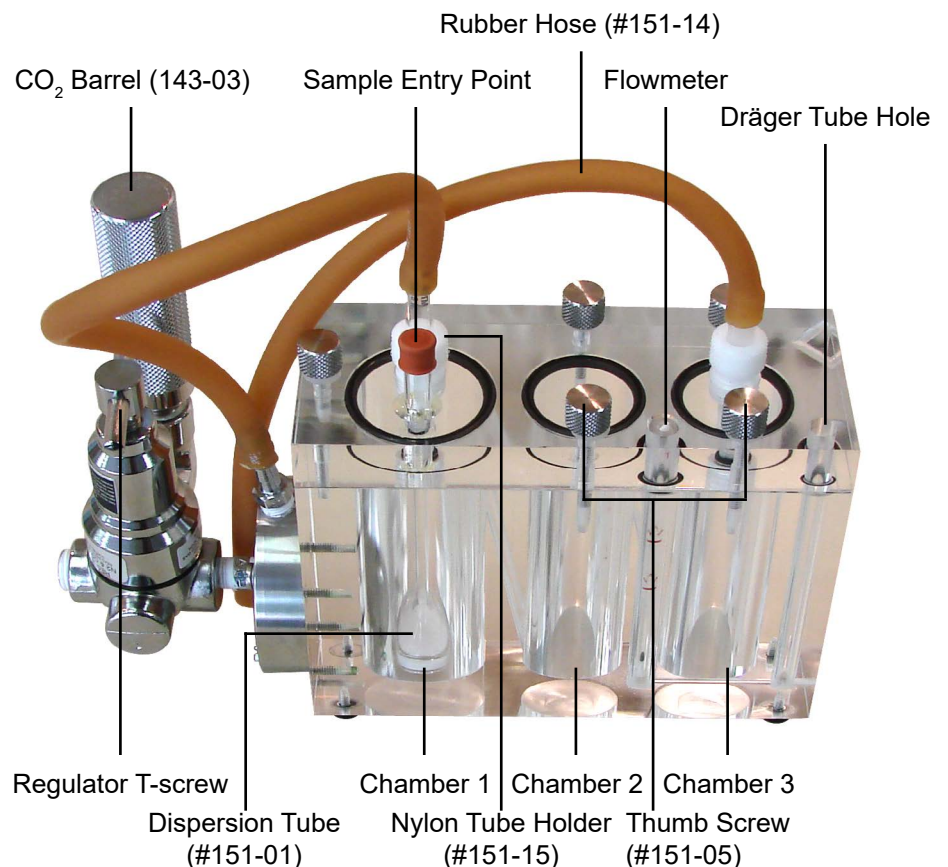



7. Unscrew (counter-clockwise) the regulator T-screw completely. Remove the cartridge holder and place a new cartridge inside. Tighten the cartridge holder until the cartridge inside is punctured.

For sulfide analysis, use CO_2 gas. For carbonate analysis, use N_2O gas.

8. Connect the regulator to the dispersion tube with one of the provided rubber hoses. Connect the other rubber hose to the nylon fitting on chamber 3.
9. Gently flow gas through the system for 30 seconds by tightening the regulator T-screw. This will purge any remaining air from the system. Check for leaks, then shut off the flow of gas.



Dispersion Tube
(#151-01)

Sulfide Testing

The concentration of soluble sulfides, including hydrogen sulfide (H_2S), sulfide (S^{2-}), and (HS^-) ions may be determined with the Garrett Gas Train. Mud filtrate is acidified in the gas train, which converts all of the sulfides to H_2S . The H_2S is then evolved by bubbling an inert carrier gas, usually carbon dioxide (CO_2), through the sample. The gas train separates the gas from the liquid. The gas stream is then passed through a Dräger tube which responds to H_2S by darkening along its length. The length of the darkened strip is proportional to the total sulfides in the mud filtrate. The low range Dräger tube turns from white to brownish-black and the high range tube turns from pale blue to jet black. No common drilling fluid contaminant will cause these color changes. Lead acetate paper disks may be used qualitatively to determine the presence or absence of sulfides. If the presence of sulfide is indicated by a darkening of the lead acetate paper, a Dräger tube may then be used for quantitative analysis.

Sulfide Testing

Procedure

1. Using the table below, determine the sample volume and type of Dräger tube required for your test.

Sulfide Range (mg/L)	Sample Volume (mL)	Dräger Tube Identification	Tube Factor (Used in Equation)
1.2 to 24	10.0	H ₂ S 100/a	.12
2.4 to 48	5.0	H ₂ S 100/a	.12
4.8 to 96	2.5	H ₂ S 100/a	.12
60 to 1,020	10.0	H ₂ S 0.2%/A	1500
120 to 2,040	5.0	H ₂ S 0.2%/A	1500
240 to 4,080	2.5	H ₂ S 0.2%/A	1500

2. Break the tip from each end of the Dräger tube and place it in the designated hole next to chamber 3. Make sure the arrow on the tube is pointing downward and that the o-ring seals around the tube.
3. Connect the rubber hose from chamber 3 to the Dräger tube.
4. With a filter press, collect a sufficient volume of solids free filtrate for analysis. If a low concentration of soluble sulfides is to be detected, a large volume of filtrate will be required. Use the table above as a guide.

During the sampling, filtration, and preparation process, the sample should not be exposed to air for an extended period of time. Sulfides can be lost rapidly due to air oxidation.

5. Fill the syringe with the measured amount of solid-free filtrate. Place a rubber septum over the sample entry point above chamber 1. Force the needle through the septum and inject the filtrate into chamber 1.
6. Slowly inject 10 mL of 5N sulfuric acid solution into chamber 1 through the rubber septum using the syringe and needle.
7. Immediately start the CO₂ gas flow. Adjust the rate such that the ball in the flowmeter stays between the two lines. One CO₂ bulb should provide about 15 to 20 minutes of flow at this rate.



Important

8. Watch for changes in the appearance of the Dräger tube. Before the front starts to smear, note and record the maximum darkened length in units marked on the tube. Continue flowing for a total of 15 minutes, even though the front may attain a diffuse and feathery coloration. In the high range tube, an orange color caused by SO_2 may appear ahead of the black front if sulfites are present in the sample. The orange SO_2 region should be ignored when recording the darkened length. For more accurate results, the darkened length should fill more than half of the tubes total length. Therefore, the filtrate sample volume must be carefully selected.
9. A lead acetate paper disk fitted under the o-ring in chamber 3 may be substituted for the Dräger tube in the gas train. The lead acetate paper will show qualitatively the presence or absence of sulfides in the sample. A dark discoloration of the paper is a positive indication of sulfides. After a positive indication, the Dräger tube should be used on a separate sample for quantitative analysis.

Sulfide Testing

Calculation

Using the measured sample volume, the Dräger tube's maximum darkened length and the Dräger tube factor from the table, calculate the sulfides in the sample.

$$\text{Sulfide (mg/L)} = \frac{(\text{Darkened tube length}) \times (\text{Tube Factor})}{\text{Sample Volume (mL)}}$$

Carbonates Testing

The concentration of soluble carbonates in a drilling fluid filtrate can be determined using the Garrett Gas Train. Total soluble carbonates include CO_2 as well as the carbonate (CO_3^{-2}) and bicarbonate (HCO_3^-) ions. Mud filtrate is acidified in the gas train, converting all carbonates to CO_2 , which is then evolved by bubbling nitrous oxide gas through the sample. The gas train separates the gas from the liquid which is collected in a 1-liter gas bag to allow the CO_2 to mix uniformly, and is subsequently drawn through a Dräger tube at a fixed flow rate. The Dräger tube will respond to CO_2 by progressively staining purple along its length. A reaction between CO_2 and a hydrazine chemical causes a crystal violet indicator to turn purple. The stain length is proportional to the total carbonate concentration in the filtrate.

Carbonate Testing

Procedure

1. Check the gas bag for leaks. To do this, collapse the bag and then connect the bag and stopcock to the hand pump, using a discarded Dräger tube as the connection. Fully depress and release the hand pump. When the bag is completely empty and free of leaks, the pump will remain depressed for several minutes. If a leak is detected, check the pump and all connections. To check the pump alone, insert a sealed Dräger tube into the pump opening and depress the bellows. It will remain depressed if the pump does not leak.
2. With the bag now fully collapsed, close the stopcock and connect the rubber tubing from chamber 3 to the closed stopcock.

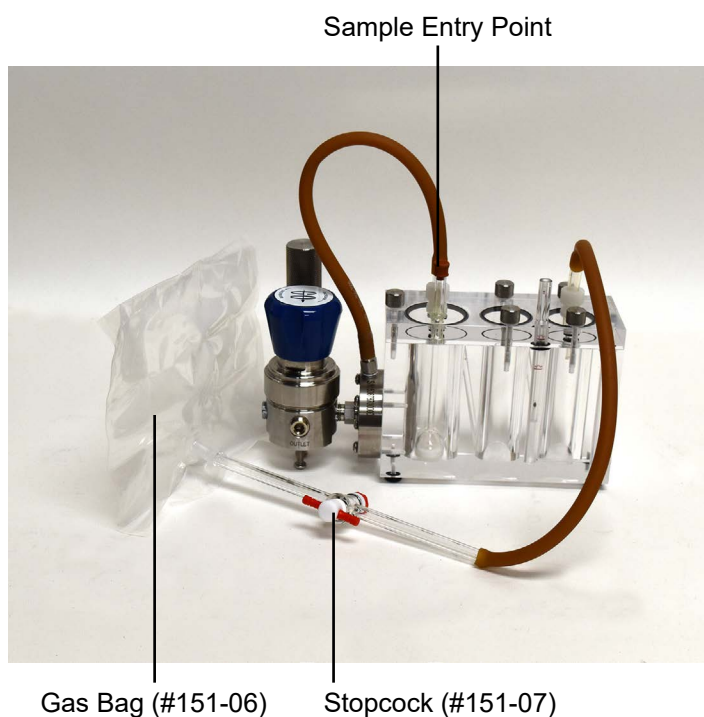

3. Using the table below, determine the sample volume and type of Dräger tube required for your test.

Carbonate Range (mg/L)	Sample Volume (mL)	Dräger Tube Identification	Tube Factor (Used in Equation)
25 to 750	10.0	CO ₂ 100/a	2.5
50 to 1,500	5.0	CO ₂ 100/a	2.5
100 to 3,000	2.5	CO ₂ 100/a	2.5
250 to 7,500	10.0	CO ₂ 100/a	2.5

4. Fill the syringe with the measured amount of solid-free filtrate. Place a rubber septum over the sample entry point above chamber 1. Force the needle through the septum and inject the filtrate into chamber 1.



Tip

5. Slowly inject 10 mL of 5N sulfuric acid solution into chamber 1 through the rubber septum using the hypodermic syringe and needle.

Over-fill the syringe by at least 0.5 mL so an exact amount may be injected.

6. Loosen the nylon tube holder and lower the dispersion tube to about ¼" from the bottom of the chamber.
7. Open the stopcock on the gas bag. Restart the flow of N₂O by tightening the regulator T-screw. Allow the gas bag to fill slowly and steadily for ten minutes. When the bag is firm to the touch, shut off the flow of gas by unscrewing the regulator T-screw. Close the stopcock to seal off the bag.
8. Immediately break the tip off each end of the Dräger tube. Remove the rubber hose from the chamber 3 connection and connect the end of the hose to the upstream end of the Dräger tube. An arrow on the Dräger tube indicates the gas flow direction. Connect the hand pump to the other end of the Dräger tube. The arrow on the Dräger tube should point from the bag toward the hand pump.
9. Open the stopcock on the gas bag. With steady hand pressure, fully depress the hand pump. Release the pump so that gas flows out of the bag and through the Dräger tube. Operate the pump and count the strokes required to empty the bag. If it takes more than ten strokes to empty the bag there is probably a leak in the system and the test will be invalidated.

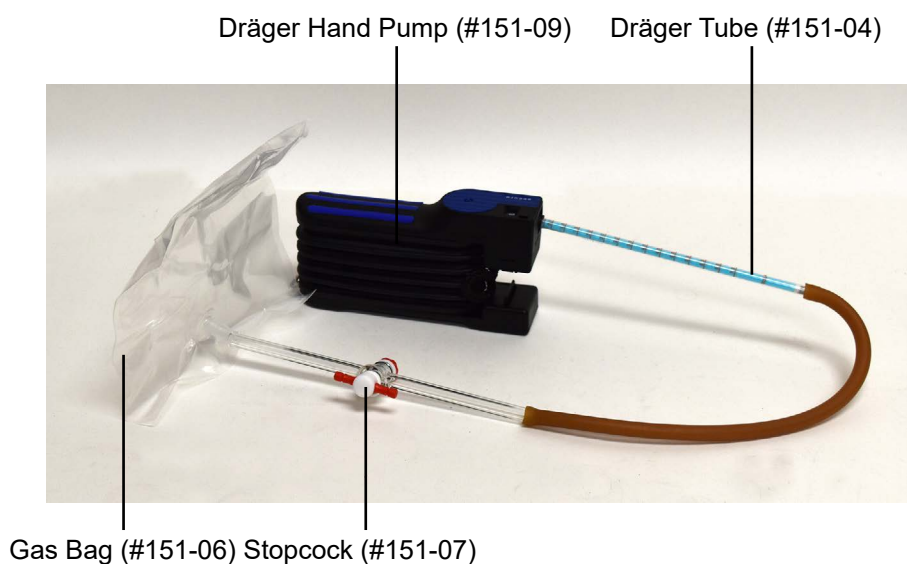

10. If CO₂ is present in the gas bag, the Dräger tube will turn purple. Record the stain length in units marked on the Dräger tube and include any faint blue tinge color that may develop as part of the total stain reading. For more accurate results, the darkened length should fill more than half of the total length of the tube. Therefore, the filtrate sample volume must be carefully selected.

Carbonate Testing

Calculation

Calculation:

Using the measured sample volume, the Dräger tube stain length, and the tube factor of 2.5 (from the table on page 13) calculate the total soluble carbonates ($\text{CO}_2 + \text{CO}_3^{-2} + \text{HCO}_3^{-}$) in the filtrate sample using the following equation:

$$\text{Carbonate (mg/L)} = \frac{2.5 (\text{Darkened Stain Length})}{\text{Sample Volume (mL)}}$$

Oil-Based Fluids

Whole oil mud (not filtrate) should be analyzed in order to capture all of the “active sulfides”. Oil muds consisting of liquid and solid phases contain the “active sulfides” and are typically the neutralization products of hydrogen sulfide (H_2S) and lime plus any unreacted H_2S . By using a 2M citric acid which is a weak acid, inert sulfides (such as solid ZnS , CuS , or PbS) are not measured and only active sulfides are analyzed.



Sample Injection Tube

Oil-Based Fluids

Procedure

1. Place the stirring bar from the magnetic stirrer into chamber 1.
2. Assemble the gas train apparatus for normal sulfide testing (see pages 6 and 7 for instructions).
3. Place the gas train apparatus on top of the magnetic stirrer.
4. Using the table below, determine the sample volume and type of Dräger tube required for your test.

Sulfide Range (mg/L)	Sample Volume (mL)	Dräger Tube Identification	Tube Factor (Used in Equation)
1.2 to 24	10.0	H ₂ S 100/a	.12
2.4 to 48	5.0	H ₂ S 100/a	.12
4.8 to 96	2.5	H ₂ S 100/a	.12
60 to 1,020	10.0	H ₂ S 0.2%/A	1500
120 to 2,040	5.0	H ₂ S 0.2%/A	1500
240 to 4,080	2.5	H ₂ S 0.2%/A	1500

5. Break the tip from each end of the Dräger tube and place it in the designated hole next to chamber 3. Make sure the arrow on the tube is pointing downward and that the o-ring seals around the tube.
6. Insert the sample injection tube through the rubber septum on top of chamber 1, being sure that it seals in the septum.
7. Add 20 mL of the 2M Citric acid, demulsifier, and isopropanol mixture (#151-20-1) into chamber no. 1.
8. Add 10 drops of octyl defoamer to chamber 1.
9. Operate the magnetic stirrer at a moderate speed. Carefully lower the dispersion tube into the circulating liquid to a point just above the rotating stirring bar.
10. With a syringe, slowly inject the correct sample volume of oil mud allowing it to mix into the vortex from the stirring bar. Stir for at least 2 minutes.

Over-fill the syringe by at least 0.5 mL so an exact amount can be injected.
11. Immediately start the CO₂ gas flow. Adjust the rate such that the ball in the flowmeter stays between the two lines. One CO₂ bulb should provide about 15 to 20 minutes of flow at this rate.



Tip

12. Watch for changes in the appearance of the Dräger tube. Before the front starts to smear, note and record the maximum darkened length in units marked on the tube. Continue flowing for a total of 15 minutes, even though the front may attain a diffuse and feathery coloration. In the high range tube, an orange color caused by SO₂ may appear ahead of the black front if sulfites are present in the sample. The orange SO₂ region should be ignored when recording the darkened length. For more accurate results, the darkened length should fill more than half of the tubes total length. Therefore, the filtrate sample volume must be carefully selected.

Oil-Based Fluids

Calculation

Using the measured sample volume, the Dräger tube's maximum darkened length and the Dräger tube factor from the table, calculate the sulfides in the sample.

$$\text{Sulfide (mg/L)} = \frac{(\text{Darkened tube length}) \times (\text{Tube Factor})}{\text{Sample Volume (mL)}}$$

Maintenance

1. Thoroughly clean the gas train after every test.
 - a. Remove the rubber tubing from the train and then remove the top.
 - b. Remove the Dräger tube and flowmeter from the train body. Plug the holes with stoppers to keep them dry.
 - c. Using a soft brush, wash out the chambers with warm water and a mild detergent.
 - d. Use a pipe cleaner to clean out the passages between the chambers.
 - e. Wash and rinse the dispersion tube. Blow air or CO₂ gas through it.
 - f. Rinse the entire unit with deionized water and allow it to drain dry.
2. Periodically replace the gas bag to avoid leaks and contamination in the system. Usually it is best to replace the bag after ten tests.
3. To clean the dispersion tube frits and injection tube, rinse with Arcosolv PNP first and then water. Blow out the frits with gas. Occasionally soak the dispersion tube in a strong acid solution (HCL - 20%) to remove calcium carbonate deposits

Diagram

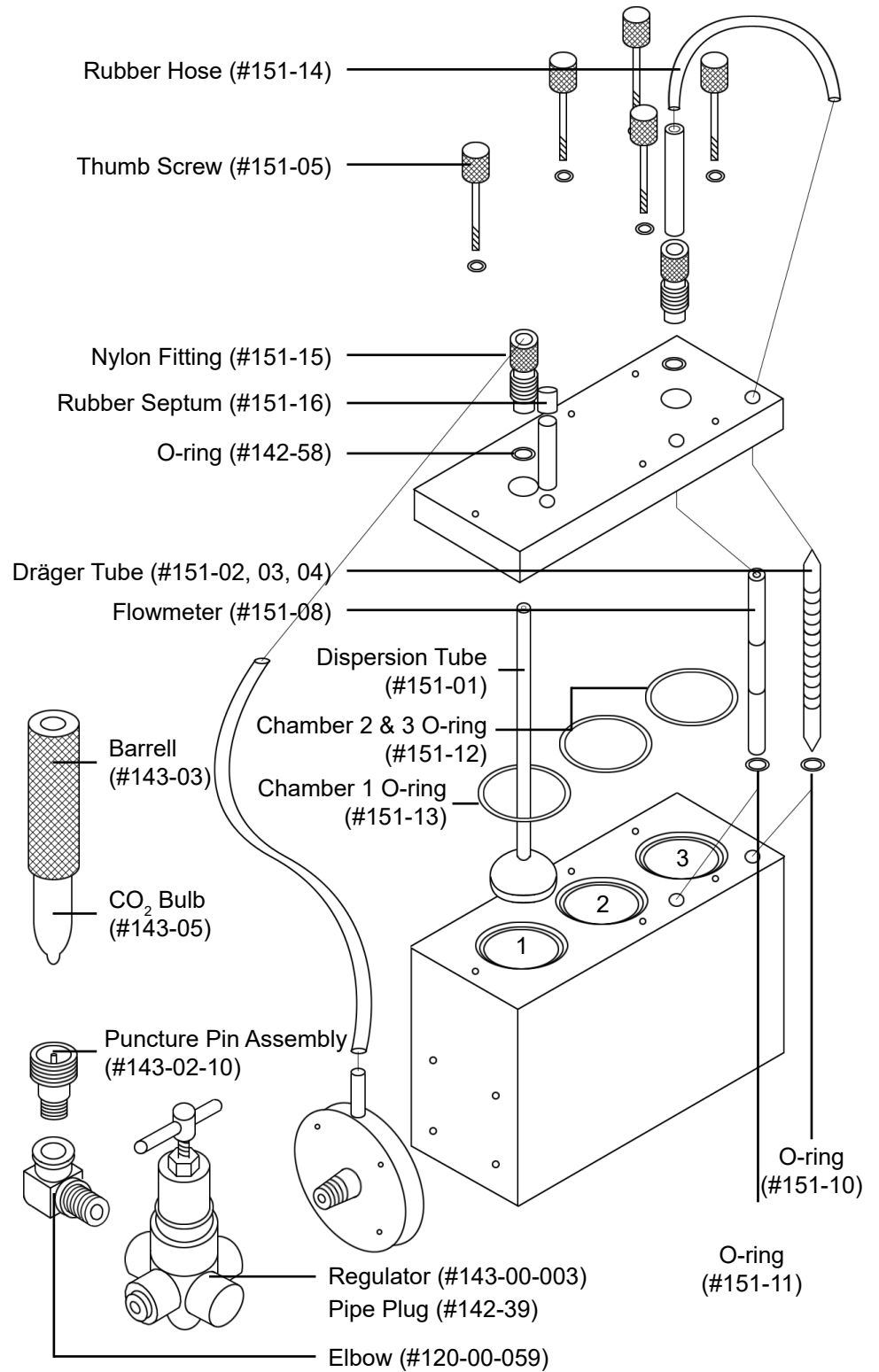

Warranty and Return Policy

Warranty:

OFI Testing Equipment, Inc. (OFITE) warrants that the products shall be free from liens and defects in title, and shall conform in all respects to the terms of the sales order and the specifications applicable to the products. All products shall be furnished subject to OFITE's standard manufacturing variations and practices. Unless the warranty period is otherwise extended in writing, the following warranty shall apply: if, at any time prior to twelve (12) months from the date of invoice, the products, or any part thereof, do not conform to these warranties or to the specifications applicable thereto, and OFITE is so notified in writing upon discovery, OFITE shall promptly repair or replace the defective products. Notwithstanding the foregoing, OFITE's warranty obligations shall not extend to any use by the buyer of the products in conditions more severe than OFITE's recommendations, nor to any defects which were visually observable by the buyer but which are not promptly brought to OFITE's attention.

In the event that the buyer has purchased installation and commissioning services on applicable products, the above warranty shall extend for an additional period of twelve (12) months from the date of the original warranty expiration for such products.

In the event that OFITE is requested to provide customized research and development for the buyer, OFITE shall use its best efforts but makes no guarantees to the buyer that any products will be provided.

OFITE makes no other warranties or guarantees to the buyer, either express or implied, and the warranties provided in this clause shall be exclusive of any other warranties including ANY IMPLIED OR STATUTORY WARRANTIES OF FITNESS FOR PURPOSE, MERCHANTABILITY, AND OTHER STATUTORY REMEDIES WHICH ARE WAIVED.

This limited warranty does not cover any losses or damages that occur as a result of:

- Improper installation or maintenance of the products
- Misuse
- Neglect
- Adjustment by non-authorized sources
- Improper environment
- Excessive or inadequate heating or air conditioning or electrical power failures, surges, or other irregularities
- Equipment, products, or material not manufactured by OFITE
- Firmware or hardware that have been modified or altered by a third party
- Consumable parts (bearings, accessories, etc.)

Returns and Repairs:

Items being returned must be carefully packaged to prevent damage in shipment and insured against possible damage or loss. OFITE will not be responsible for equipment damaged due to insufficient packaging.

Any non-defective items returned to OFITE within ninety (90) days of invoice are subject to a 15% restocking fee. Items returned must be received by OFITE in original condition for it to be accepted. Reagents and special order items will not be accepted for return or refund.

OFITE employs experienced personnel to service and repair equipment manufactured by us, as well as other companies. To help expedite the repair process, please include a repair form with all equipment sent to OFITE for repair. Be sure to include your name, company name, phone number, email address, detailed description of work to be done, purchase order number, and a shipping address for returning the equipment. All repairs performed as "repair as needed" are subject to the ninety (90) day limited warranty. All "Certified Repairs" are subject to the twelve (12) month limited warranty.

Returns and potential warranty repairs require a Return Material Authorization (RMA) number. An RMA form is available from your sales or service representative.

Please ship all equipment (with the RMA number for returns or warranty repairs) to the following address:

OFI Testing Equipment, Inc.
Attn: Repair Department
11302 Steeplecrest Dr.
Houston, TX 77065
USA

OFITE also offers competitive service contracts for repairing and/or maintaining your lab equipment, including equipment from other manufacturers. For more information about our technical support and repair services, please contact techservice@ofite.com.